

fujimoto

IMAGE
PROCESSOR

CP-31 OPERATION MANUAL

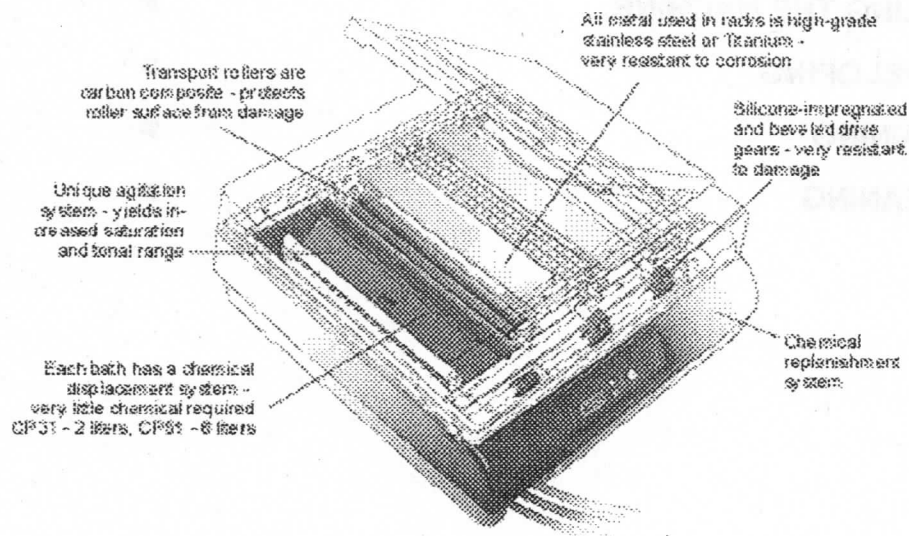

Thank you for your purchase of The Fujimoto CP-31 Image processor. Before attempting to operate this equipment, please read all of the information contained in this manual carefully. This will help the equipment demonstrate its performance and ensure its long-term service. Since the CP-31 uses chemical solutions, daily maintenance is essential for proper operation.

"Caution never turn on the unit without full solution trays"
Turning the unit on when dry will cause serious damage.

Contents

CP-31 FEATURES	▶
CP-31 SPECIFICATIONS	▶
PARTS DESCRIPTION	▶
INSTALLATION	▶
THE CONTROL PANEL	▶
THE CONTROL BOX	▶
INITIAL SET-UP AND OPERATION	▶
PREOPERATION CHECK AND CLEANING OF BATH	▶
SETTING THE SOLUTION TEMPERATURE	▶
SETTING THE TRANSPORT SPEED	▶
TEST RUN	▶

FILLING THE MACHINE

DEVELOPING

DRAINING

CLEANING



Fujimoto
MADE
PROCESSOR
CP-31
OPERATION
MANUAL

Thank you for your purchase of the Fujimoto CP-31 image processor.
Before attempting to operate this equipment, please read all of the information
contained in this manual carefully. This will help the equipment operate in
performance and ensure its long term service.
Since the CP-31 uses chemical solutions, daily maintenance is essential for proper
operation.
*Lenses never touch on the unit without the solution tray.
Turning the unit on when dry will cause serious damage.

Contents

CP-31 FEATURES
CP-31 SPECIFICATIONS
PARTS DESCRIPTION
INSTALLATION
THE CONTROL PANEL
THE CONTROL BOX
INITIAL SET-UP AND OPERATION
PREPARATION CHECK AND CLEANING OF BATH
SETTING THE SOLUTION TEMPERATURE
SETTING THE TRANSPORT SPEED
TEST RUN

CP-31 FEATURES

- The CP-31 is a 3-bath, 3-heater processor. Each bath contains a heater and agitator, automatic processing of positive/positive color Cibachrome P-30), negative/positive color (EP2 and similar) and conventional B&W.
- Developing can be performed in ordinary room light by simply closing the shield cover.
- Paper sizes from 12 x 16 inch to 83 x 108mm can be processed.
- Automatic temperature control and variable transport speed insures extremely repeatable results.
- Requires only 2 liters of processing solution.
- Solution temperature and paper transport speed are fully adjustable matching each type of paper used.
- The ventilation fan, standby function, and magnetic agitation pumps prevent problems common to other roller transport processors.
- Paper sensor detects paper feed.
- Small profile allows easy convenient placement beside an enlarger.

CP-31 SPECIFICATIONS

- **Transport System** Opposed roller transport system. processing Size - RC type paper 305 x 406mm (12 x 16inch) 483 x 108mm. (3 1/2 x 4 1/2 inch)
- **Transport Speed** 42-420mm per minute. Digital display of transport speed.
- **Processing Time** 30 seconds,45 minutes per bath (each bath is the same).
- **Processing Baths** Temperature controlled with overflow device on each bath.
- **Capacity** Each bath contains 2 liters.
- **Temperature Control**
 - **First Bath** Digital micro-computer controlled. Setting range up to 50 deg C. Accuracy +0.1 deg C. Digital display of set temperature and actual temperature. Up-down key allows setting in 0.1 deg C units.
 - **Second and Third Bath** Dial set analog temperature control. Setting range up to 50 deg C. Accuracy +0.2 deg C. Can be set independently for each bath.

***All three baths provided with an overheating shut down circuit.**

- **Agitation** Each bath is agitated by a magnetic pump.
- **Paper Sensor** IR sensor in first bath detects paper feed.
- **Standby** Feed rollers and agitation will automatically stop when the processor is not used for more than 45 minutes, then runs intermittently for 3 seconds at an interval of 15 seconds. The standby function will release and return to normal operation when paper is inserted.
- **Ventilation Fan** Equipped with a ventilation fan for discharging humidity.
- **Chemical Drain** Drained independently from each bath by a drain pipe.
- **Power Source** 230/115 volt 50/60 cycles
- **General Dimension** 23.50 x 24.00 x 9.75 inches
1600 x 610 X 250mm (Depth X Width X Height)
- **Dry weight** 29kg/64 pounds
- **Accessories** One 5A Fuse, 2 Funnels
- **Options** Auto replenishment and wash/dry module.

PARTS DESCRIPTION

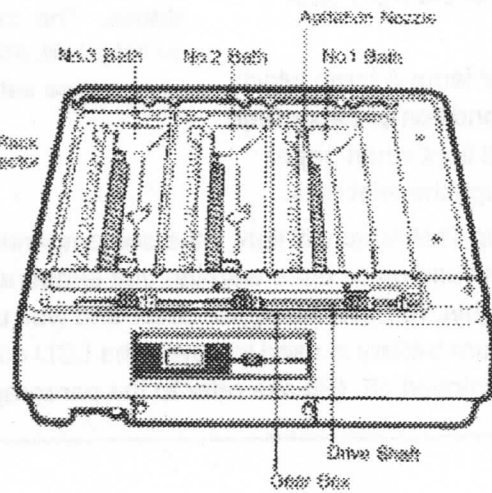
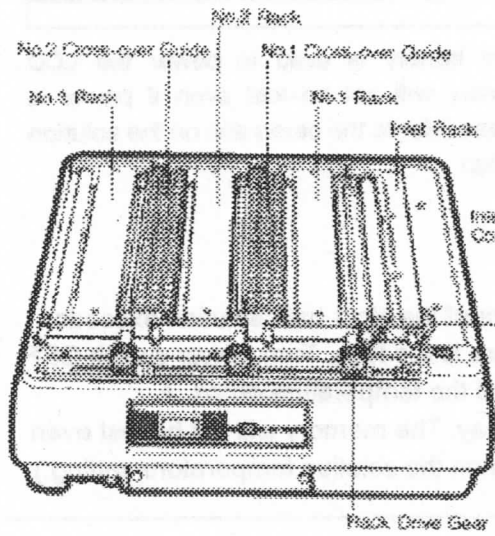
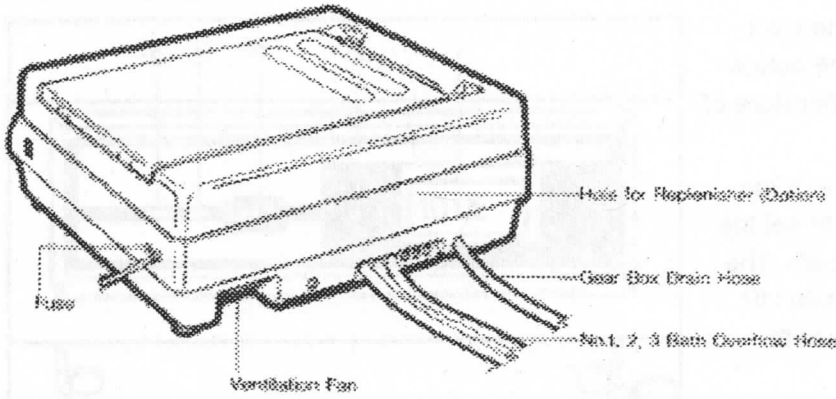
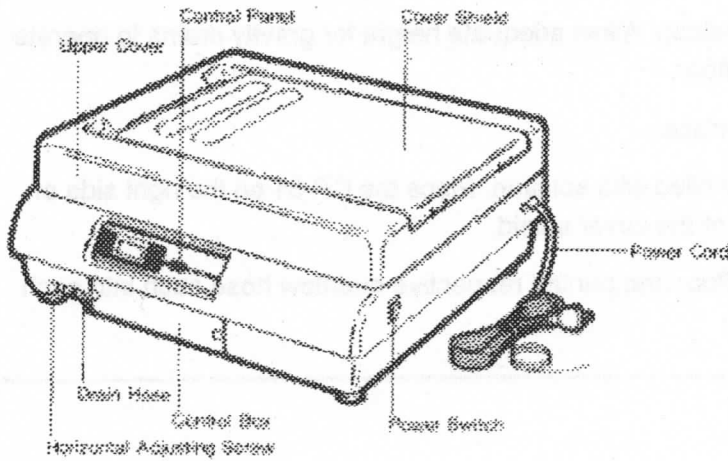

Accessories: Two funnels, SA fuse span.

INSTALLATION

- Install the CP-31 on a table or desktop. Allow adequate height for gravity drains to operate properly. Avoid placing it on the floor.
- Level the CP-31 on your work surface.
- Do not move the CP-31 once it is filled with solution. Place the CP-31 on the right side of the enlarger to facilitate opening of the cover shield.
- Set 1/2 gallon containers on the floor and put the respective overflow hose each into each containers.

THE CONTROL PANEL

- 1 Temperature display of the No.1 bath solution. Indicates the actual temperature and set temperature of the solution.
- 2 Set button for temperature of the No.1 bath solution. Used to set the temperature of the No.1 bath. The set temperature will rise with UP and temperature will drop with DOWN,
- 3 Set button This is used for setting the upper and lower limit of the temperature of the No.1 bath solution.
- 4 Paper sensor lamp A lamp which shows the condition of paper feed. The lamp will light when paper passes through the inlet rack.
- 5 Warning lamp This lamp will light if the set temperature of the No.1 bath solution exceeds the upper limit and gives out a warning that temperature is too high. Turn power switch OFF if the lamp lights, remove the upper cover and wait until the temperature drops. A nickel-cadmium battery is used to power the LCD display. The memory will not be lost even if power is switched off. (Please refer to the paragraph on the solution temperature setting.)

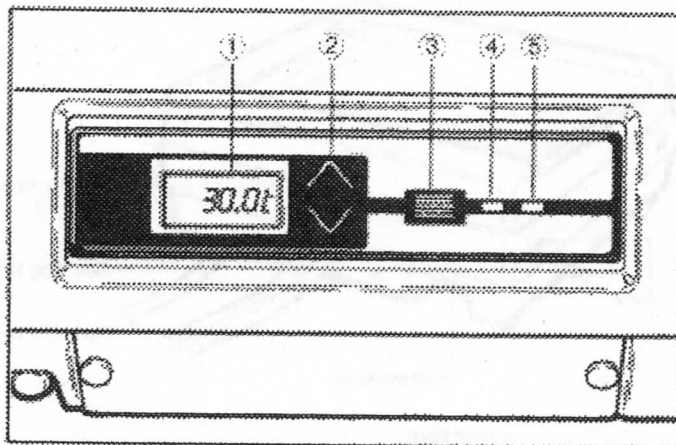

A nickel-cadmium battery is used to power the LCD display. The memory will not be lost even if power is switched off. (Please refer to the paragraph on the solution temperature setting.)

THE CONTROL BOX

- 1 Dial for setting temperature of solution This is for setting the temperature of the No.2 and No. 3 baths.
- 2 Solution temperature pilot lamp The lamp will light when heater is actuated and goes off when the heater is off.
- 3 Dial for setting transport speed. This dial is for setting the transport speed (processing time) of paper.
- 4 Transport speed display. Displays the transport speed of paper in units of mm/min. Refer to table on page 18 for the relationship between transport speed and processing time.

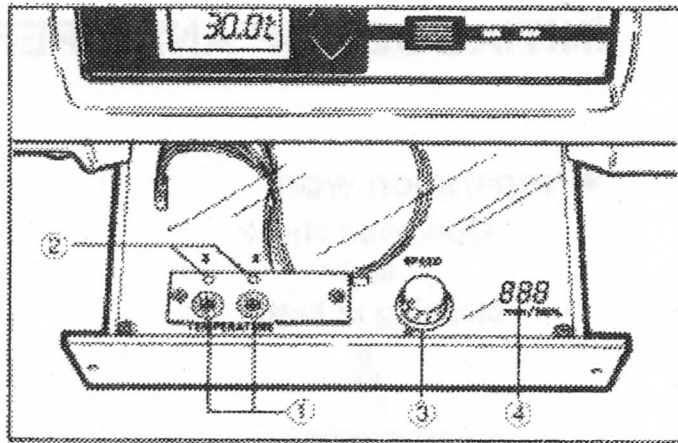

INITIAL SET-UP AND OPERATION

◆Preparation work

Operation check
and
cleaning of bath ▶



Pour in water for
level adjustment. ▶



Cleaning bath ▶



Power switch ON.
Check operation of drive moter and agitation.
Power switch OFF.

Use
water Setting temperature
of solution. ▶



Power switch ON.
Set temperature of solution.

Setting of
transport speed. ▶



Test run. ▶



Insert paper and check deveveloping operation with
water.
Power switch OFF.

Drain water. ▶

Pour in processing solution.



Carefully mix each solution.
Power switch ON.

Processing
solution.

5 minute standby.



Stabilization of solution
temperature.

Preparation completed.

◆ **Developing Operation**

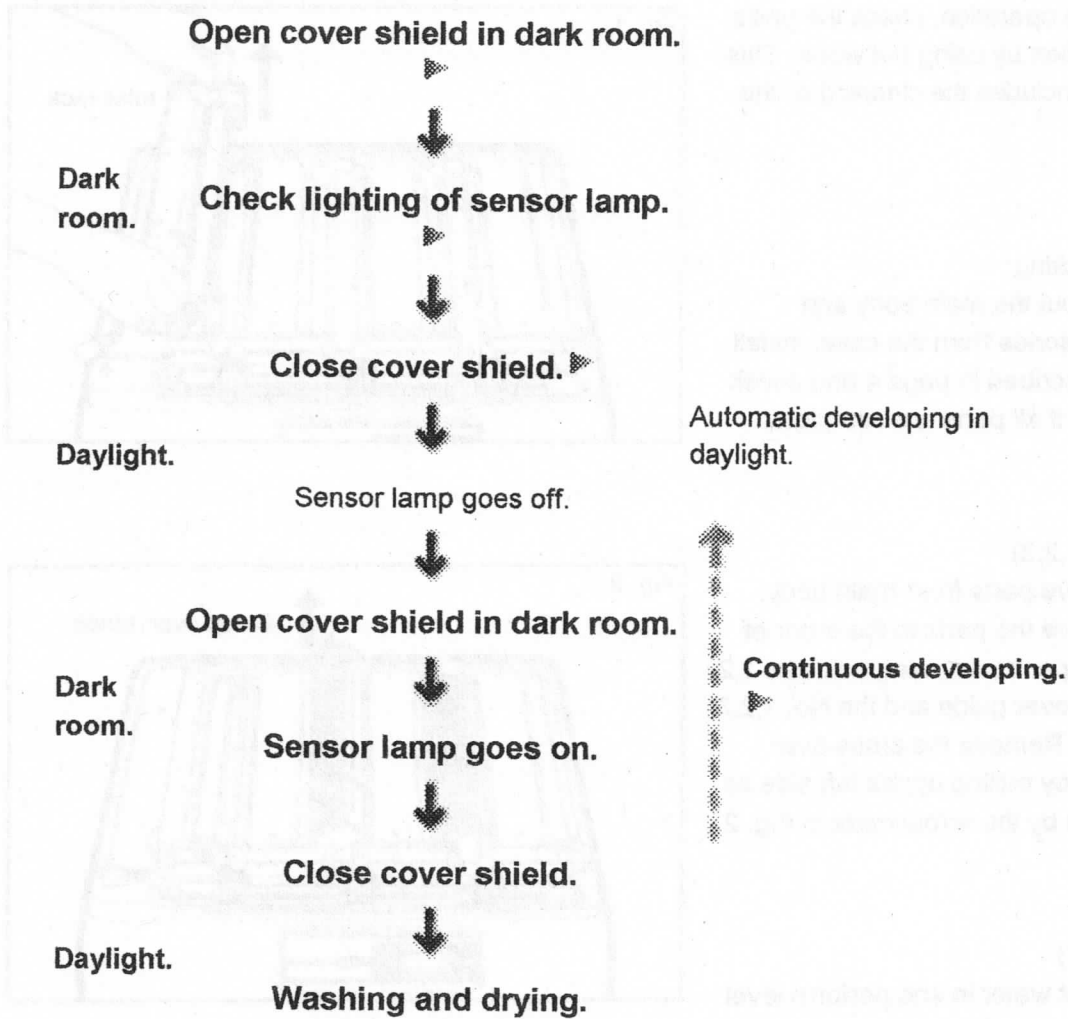

◆ **Cleaning.**

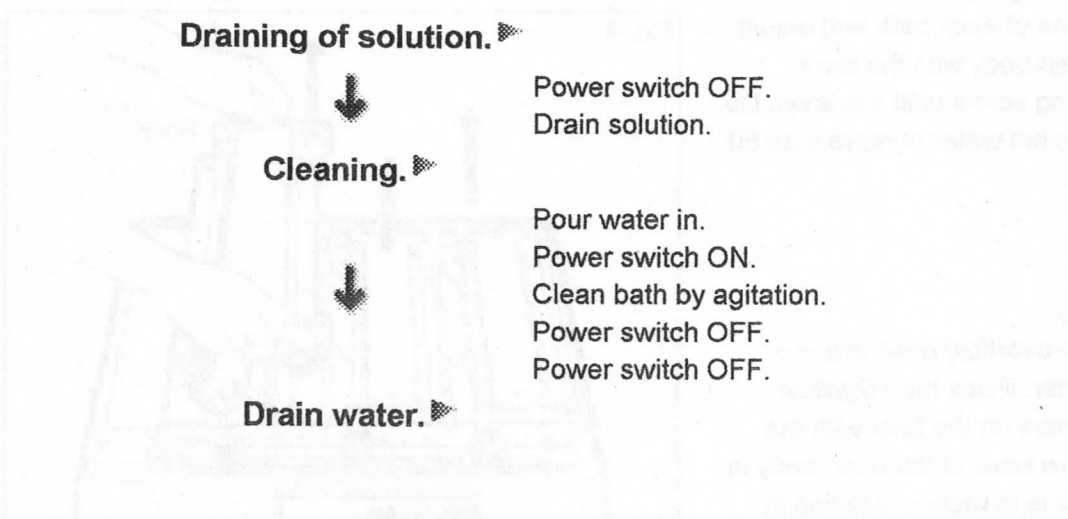

PREOPERATION CHECK AND CLEANING OF BATH

Before operation, check the unit's operation by using hot water. This work includes the cleaning of the bath.

1

Unpacking:

Take out the main body and accessories from the case, install as described in page 4 and check to see if all parts are complete.

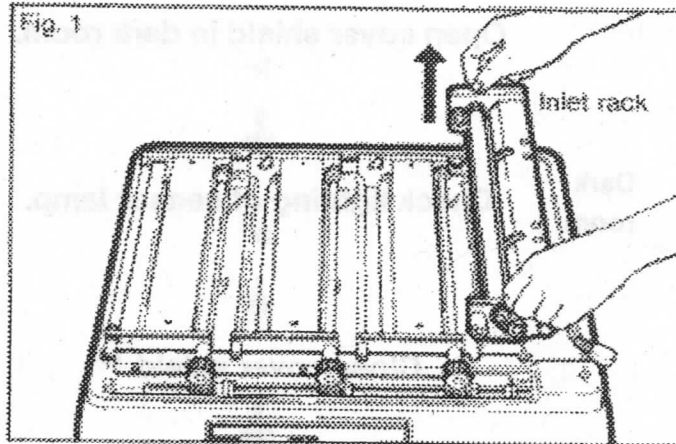

2

(Fig. 1,2,3)

Remove parts from main body.

Remove the parts in the order of the upper cover, inlet rack, No. 1,2 cross-over guide and the No. 1,2,3 racks. Remove the cross-over guide by pulling up the left side as shown by the arrow mark in Fig. 2.

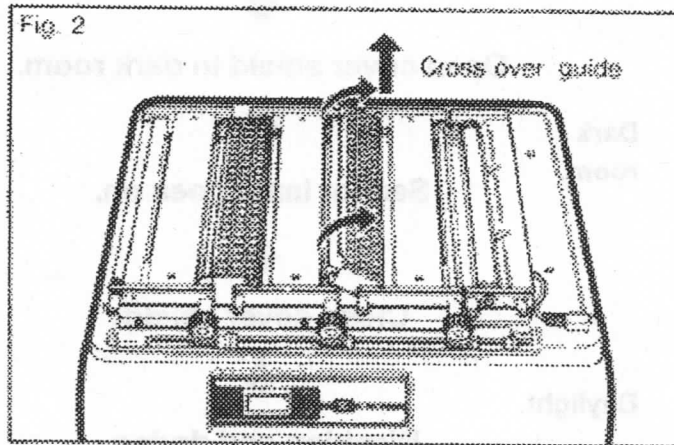

3

(Fig. 4)

Put hot water in and perform level adjustment. Put hot water in which is 1 C deg - 2 C deg higher than the processing temperature up to the level line of each bath and adjust the main body with the level adjusting screw until it is level. Do not use hot water of more than 50 C deg.

4

(Fig. 5)

Put the overflow hose into the container. Place the 1/2gallon containers on the floor with the overflow hose of the main body in it. (This is to receive solution in

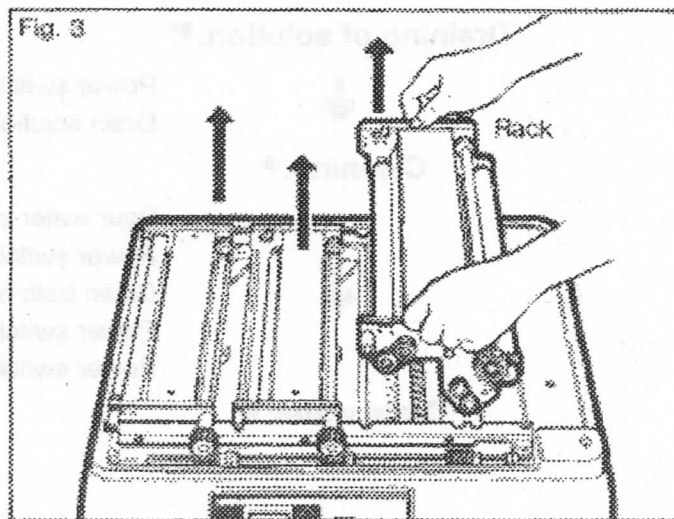

case it overflows). The gear box drain is for draining water which has entered the gear box during cleaning.

5

Actuate the main body.
Connect power cord to the power source, turn power switch ON and check if the drive motor and agitation pump are operating properly. "Do not heat without solution!". Never turn the power switch ON without water or solution in each bath. The unit is working properly if the drive shaft starts to turn slowly and water spouts from the agitation nozzle.

● Standby Mechanism.

The drive motor and the agitation pump will operate continuously for about 45 minutes after turning power switch ON and then operate intermittently for 3 seconds at an interval of 15 seconds. (This will stop automatically and return to continuous operation when developing). To cancel standby, turn power switch OFF and then ON again.

6

Next, set the temperature for the solution. Proceed to the page below for setting solution temperature with hot water contained in the bath.

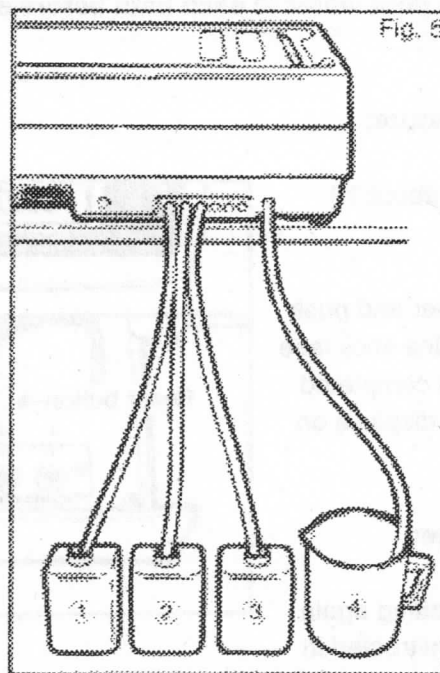
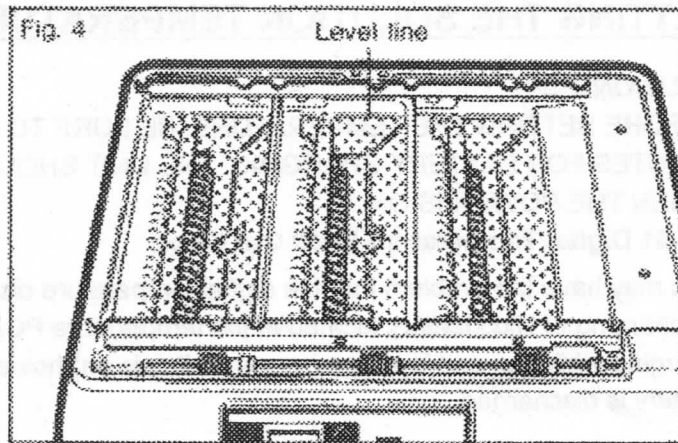

Put 4 hoses into one container when using chemical solution other than P30.

- 1: No.1 bath overflow
- 2: No.2 bath overflow
- 3: No.3 bath overflow
- 4: Gear box drain

SETTING THE SOLUTION TEMPERATURE

CAUTIONS:

BEFORE SETTING THE TEMPERATURE, BE SURE TO POWER ON THE UNIT FOR 10 MINUTES FOR BATTERY CHARGING. THE UNIT SHOULD BE FILLED WITH HOT WATER WHEN THE POWER IS ON.

CP-31 Digital Temperature Read Out Error:

You may have the problem that the digital temperature display malfunctions. This is due to the discharging of Nicd battery located at the temperature PCB. This battery is automatically charging while the unit is in use (power switch is on) however if the unit is long unattended, the battery is discharged.

To restore this situation, switch on the unit for about 10 minutes to make the battery start to charge and follow the steps on how to reset.

WARNING: Be sure to pour water to each bath before switching on the unit.

How to Reset Temperature:

1. Switch on the unit for about 10 minutes.

2. Pull out the front drawer and push the reset button with a fine stick (see figure). Now resetting is completed and actual temperature displays on the panel.

3. Push in the front drawer.

4. Do the temperature setting again from the first stage as instructed in the manual.

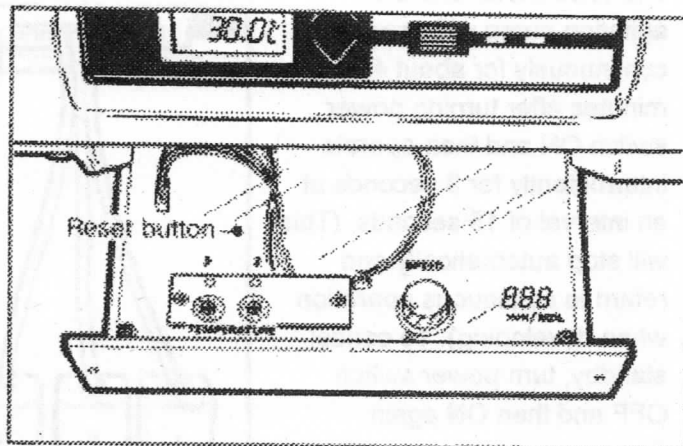

5. Make sure the small letters on the bottom of the display panel are:

THERMOMETER TEMP. CONTROLLER II POINT

If you find the letter I at II location, you have to "Reset" again and repeat the same temperature setting from the first stage as instructed in the manual.

Use hot water instead of processing solution when setting the temperature of solution. Temperature setting is performed by the control panel for the first bath and the control box for the second and third bath.

Once temperature is set, it is not necessary to make further settings.

1

Continued from Section 6 of the page above. The upper cover, inlet rack, No.1 and 2 cross-over guide and the No. 1,2,3 racks are already removed and hot water is in the bath. The power switch is turned ON.

2

(Fig. 1) Setting the temperature of the No. 1 bath solution.

(A) Continuously press the set button for more than 2 seconds, the set temperature will be displayed with a maximum value of 50cC indicating HIGH SET (warning Temperature) on the LCD display. Next, press V (DOWN) of the solution temperature set button and set the upper limit value of the set temperature. The value will change 0.1QC every time the set button is pressed and continuous pressing will keep changing the value.

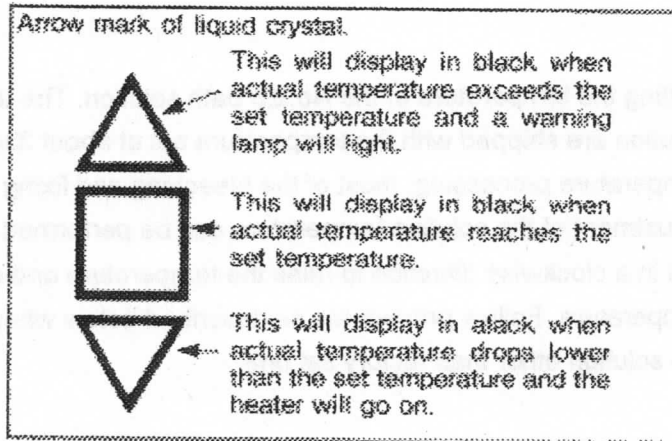
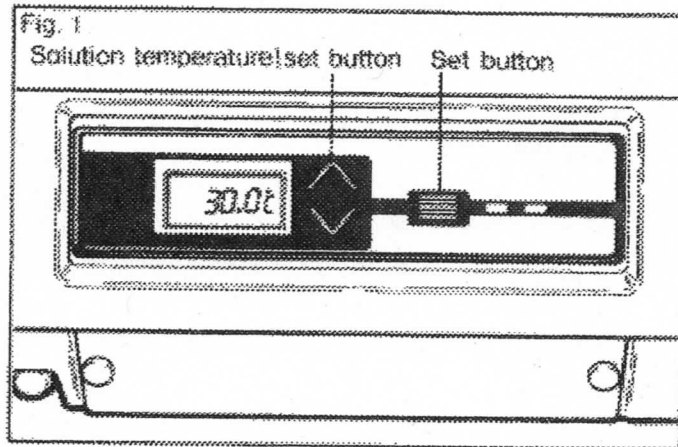

● **Upper and lower limit of set temperature.** With the processing temperature of the solution as the lower limit (example - 30 C deg.), set the upper limit 1C deg. higher (example - 31 C deg.) than the lower limit.

(B) Next, press the set button once more which will set the indicated temperature as the upper limit of the set temperature and the LCD at the same time will display - 20 C deg. as LOW SET. (Solution temperature recommended by chemistry manufacturer)

(C) In this condition and with A (up) of the temperature set button, set the lower limit value.

(D) When the set button is pressed again, the temperature which was displayed will be set (memorized) as the lower limit and will display on the LCD as shown by the arrow mark in the drawing at right. To change the set temperature, repeat the procedures of (A) ~ (D).

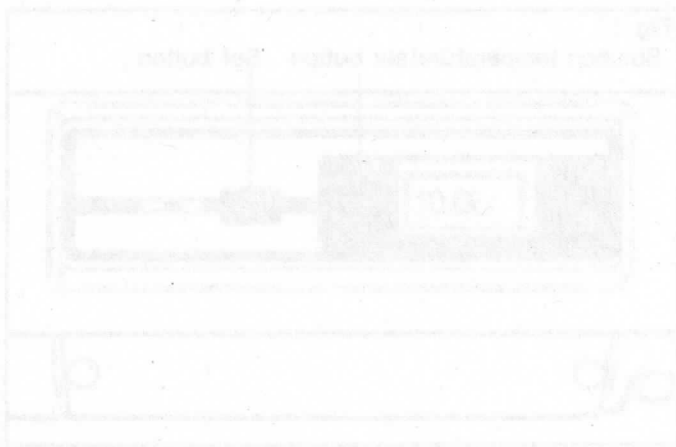

3

Setting the temperature of the No.2,3 bath solution. The temperature of the No. 2 and 3 bath solution are shipped with the temperature set at about 33°C. With the exception of high temperature processing, most of the bleaching and fixing can be used in this condition. Minute adjustment of the solution temperature can be performed by turning the temperature setting dial in a clockwise direction to raise the temperature and counterclockwise to lower the temperature. Follow procedures as described below when first setting the new temperature of the solution other than factory set one

(A) Pull out the control box and with a screw-driver, turn the temperature setting dial of the No.2 and 3 bath in a counter-clockwise direction until it stops. (Fig.2)

(B) Check the temperature of the No.2 and 3 bath with a thermometer. The solution temperature pilot lamp is off at this time.

(C) The temperature of hot water which was put in the bath as described in Section 1 of page 8 has dropped slightly. If the temperature is lower than the temperature of the thermometer which is to be set, then turn the temperature setting dial of that bath fully in a clockwise direction. The solution temperature pilot lamp will light. Wait until the solution reaches the set temperature. (Fig.3)

(D) When the temperature of the solution reaches the set temperature, turn the temperature setting dial of that bath slowly back in a counter-clockwise direction and stop where the solution temperature pilot lamp goes off. (Fig.4)

"Check temperature for 5 minutes!"

After the temperature of the solution is set, continue to check temperature for about 5 minutes to see whether the solution has stabilized. Setting is completed if the pilot lamp repeatedly blinks within the range of ± 0.2 C deg. of the set temperature. "Caution! Temperature exceeding 50 C deg. is strictly prohibited!". Avoid setting of temperature to exceed 50 C deg.

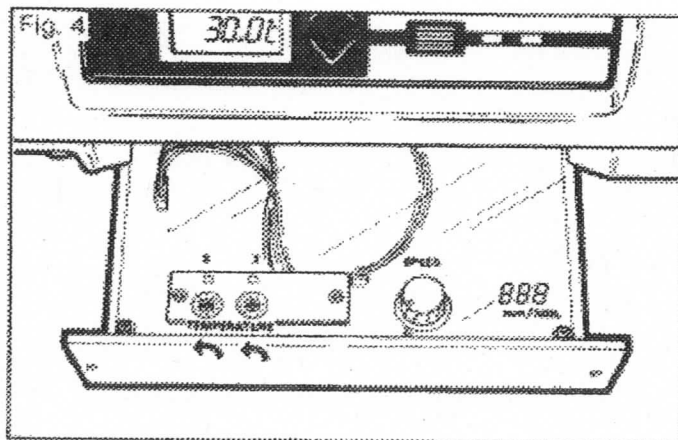
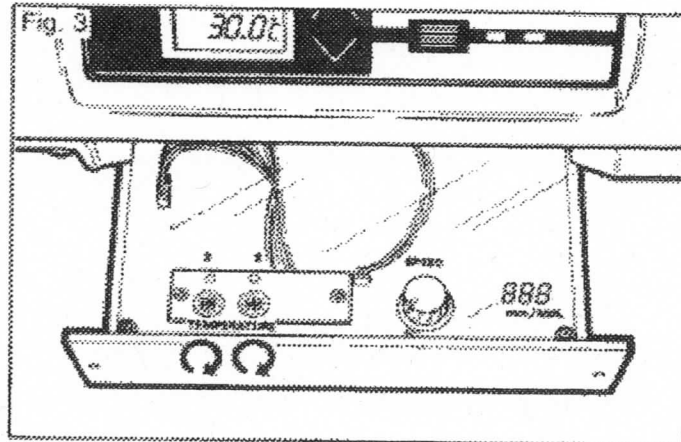
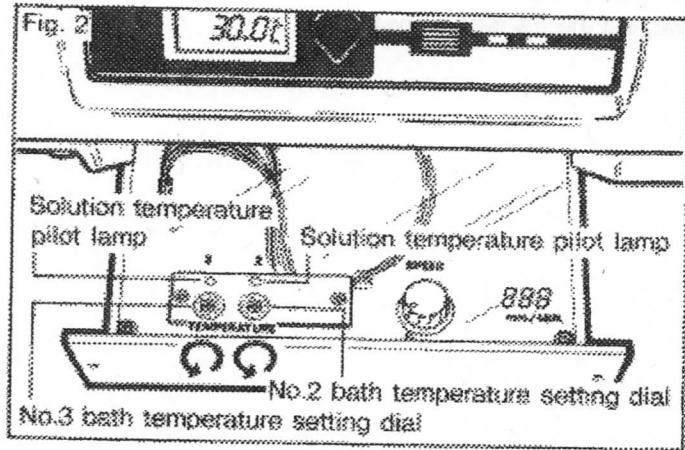

4

Turn power switch OFF.
Next, set the transport speed.

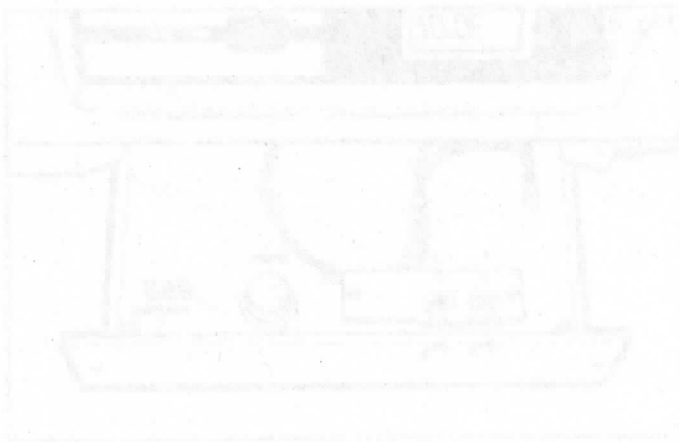
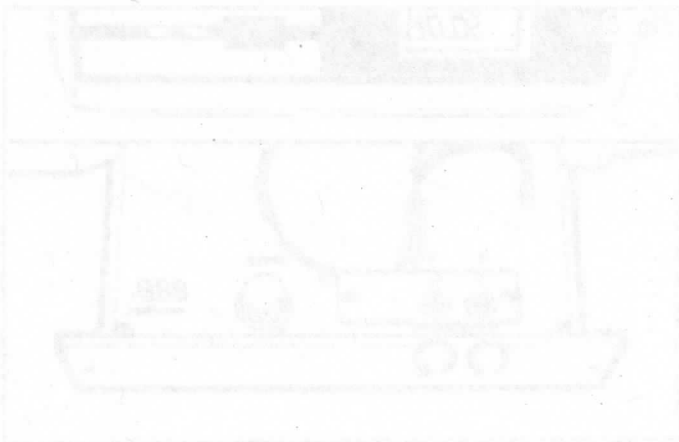
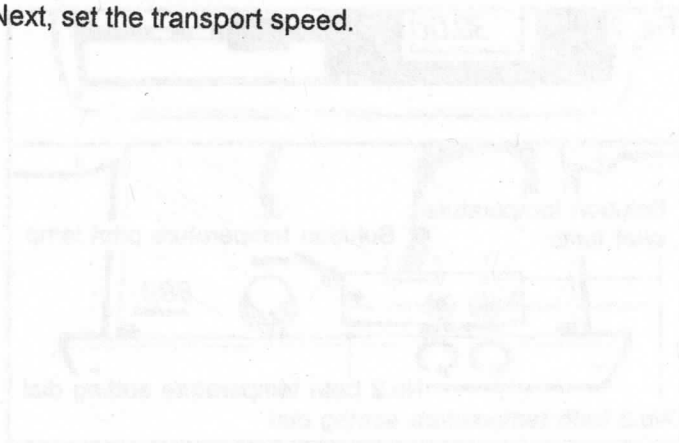

(A) Turn the power switch OFF.
The power switch is located on the front panel of the machine.
The solution temperature setting knob is located on the right side of the control panel.

(B) Check the temperature of the solution.
The solution temperature should be within the range of 20°C to 30°C.
If the temperature is outside this range, adjust the temperature setting knob.

(C) The temperature of the solution will rise if the transport speed is set too high.
If the temperature is too high, set the transport speed to a lower level.
The transport speed is controlled by the transport speed knob.
The solution temperature will rise if the transport speed is set too high.
The solution temperature will fall if the transport speed is set too low.

(D) When the temperature of the solution is set, the transport speed knob should be set to the level described in section 1 of page 2 of this manual.
The solution temperature will rise if the transport speed is set too high.
The solution temperature will fall if the transport speed is set too low.

Check temperature for 20°C.
The temperature of the solution should be 20°C.
If the temperature is not 20°C, adjust the temperature setting knob.
The solution temperature will rise if the transport speed is set too high.
The solution temperature will fall if the transport speed is set too low.

SETTING THE TRANSPORT SPEED

Set transport speed of the paper.

1

Turn power switch ON after making sure water is in each bath.

2

(Fig.1) Set the speed with the transport speed dial. Pull out the control box, turn the transport speed dial and display the speed.

3

The speed is displayed in mm/min. Though the speed is displayed in mm/min, refer to table in page 1 8 for the relation between transport speed and processing time. Each bath has the same processing time.

4

After setting the speed, turn power switch OFF.

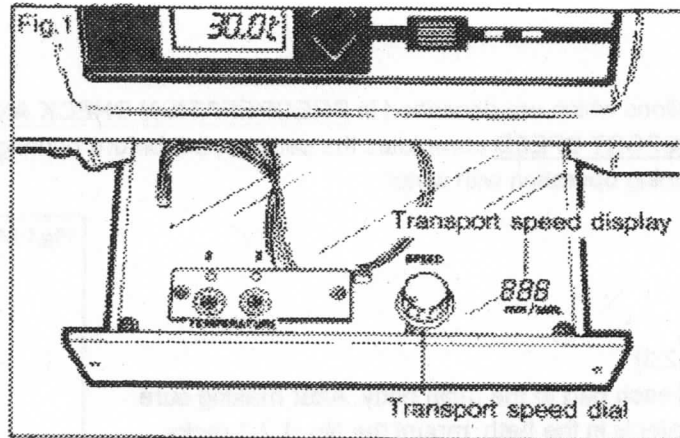

The last numeral of the speed display may change after setting, but this variation will not affect operation.

TEST RUN (Mounting of each rack, cross-over guide and upper cover)

Operations which are described in **PREOPERATION CHECK AND CLEANING OF BATH** to **SETTING THE TRANSPORT SPEED** completes the settings, but before pouring in the processing solution, pre-check developing operation with water.

1

(Fig.1,2,3)

Mount each part to the main body. After making sure that water is in the bath, mount the No. 1,2,3 racks, No.1,2 cross-over guides and then the inlet rack to the main body. Plug in the connector of the inlet rack to the connector of the main body. Water will overflow slightly when the rack is mounted. Turn power switch ON.

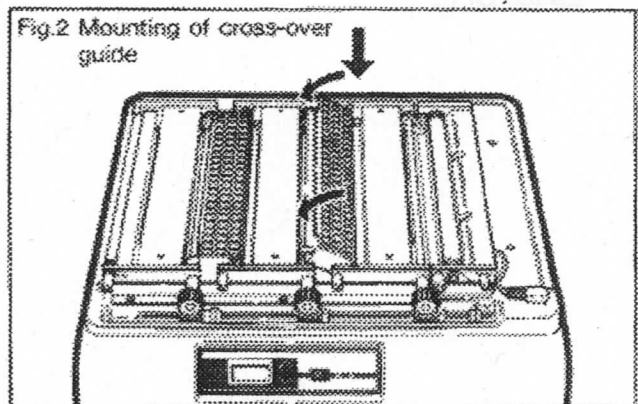
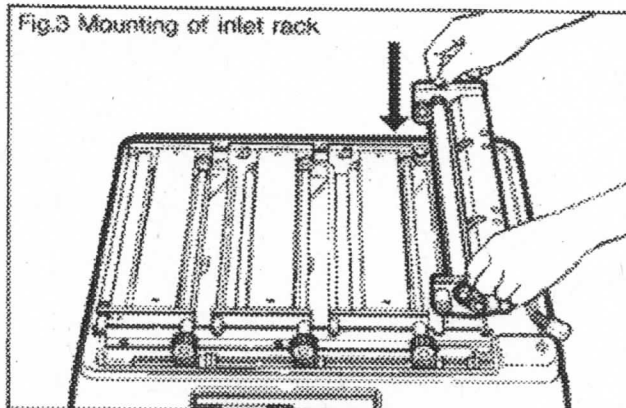
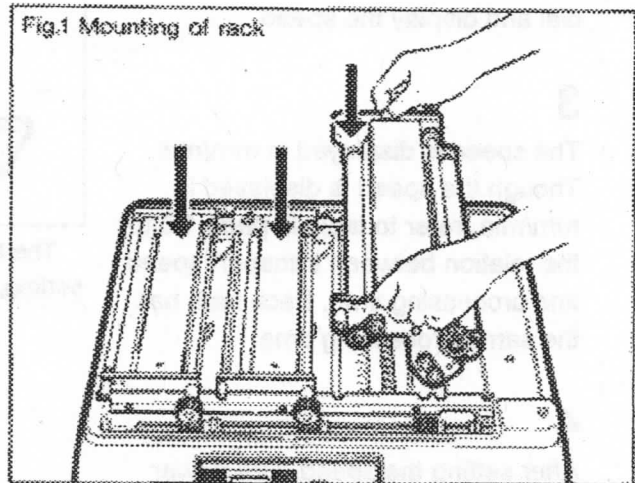

2

(Fig.4)

Check the feeding of paper. Insert the RC paper with the emulsion surface facing up. Position the paper along the guide of the inlet rack into the center of the roller. The paper will advance slowly into the bath and then come out from the outlet of the main body. Running paper clean up sheets through the machine cleans the transport rollers. Clean up sheets should be run before each developing session.

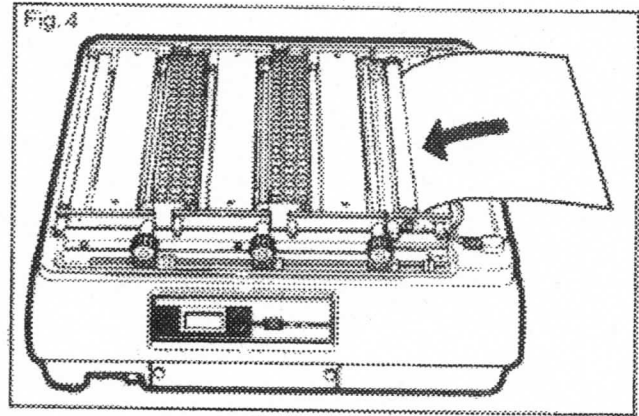
**3**

(Fig.5,6)

Mounting of upper cover. Mount the upper cover to the main body by matching the holes (2 holes) at the left side of the upper cover to the positioning pins (2 pcs) at the left side of the main body. Open the cover shield and insert the paper with the film surface facing up from the paper guide and make sure the paper sensor lamp lights on the control panel. The paper will come out slowly from the paper outlet of the main body. "Notice!" The actual developing work is performed in a dark room. This section describes a test run in ordinary room light for the purpose of checking machine operation.

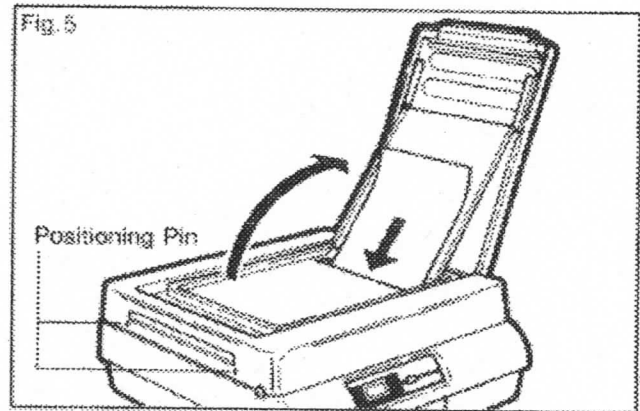
**4**

(Fig.7)

Drain water. After checking the above, turn power switch OFF, remove the cap from the drain hose and drain water from each bath. The number on the drain hose shows the number of each bath. "Caution!" Always turn power switch OFF when draining water. Draining water with the power switch ON will not only overheat the heater, but can cause seizure of the agitation pump bearings.

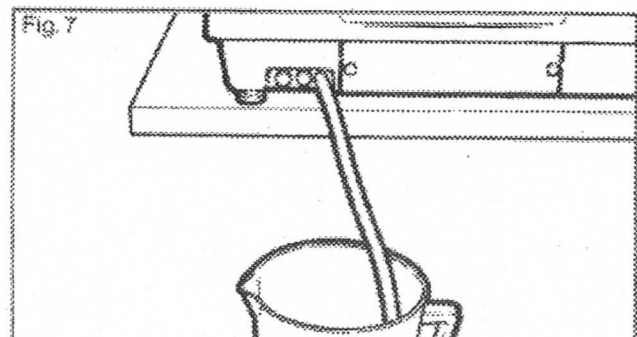
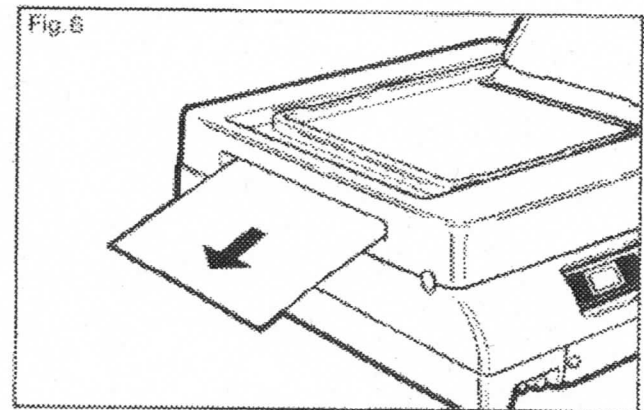



1. Check the feeding of paper. Insert the PC paper with the embossed surface facing up. Push the paper along the edge of the roller with your thumb. The paper will be drawn out from the front of the roller. The paper will be drawn out from the front of the roller. The paper will be drawn out from the front of the roller.

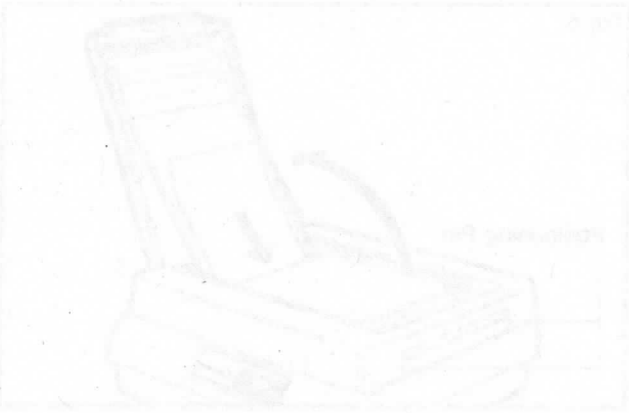

2. The paper will be drawn out from the front of the roller. The paper will be drawn out from the front of the roller. The paper will be drawn out from the front of the roller. The paper will be drawn out from the front of the roller. The paper will be drawn out from the front of the roller.



3. The paper will be drawn out from the front of the roller. The paper will be drawn out from the front of the roller. The paper will be drawn out from the front of the roller. The paper will be drawn out from the front of the roller. The paper will be drawn out from the front of the roller.



4. The paper will be drawn out from the front of the roller. The paper will be drawn out from the front of the roller. The paper will be drawn out from the front of the roller. The paper will be drawn out from the front of the roller. The paper will be drawn out from the front of the roller.

FILLING THE MACHINE

Trials up to now have been performed with water, but from this section on, processing solution will be poured in for actual developing.

1

(Fig.1,2,3) Make sure power switch is OFF. After making sure that power switch is turned OFF, remove the upper cover, inlet rack, each cross-over guides and the racks. If water is still remaining in the bath, drain it as described in Section 4 of page 11.

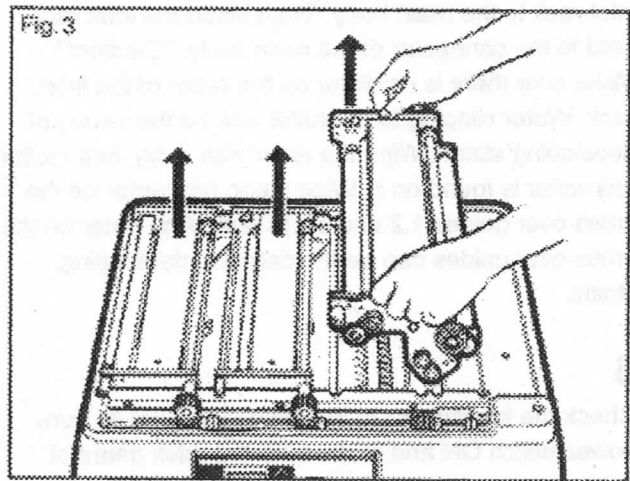
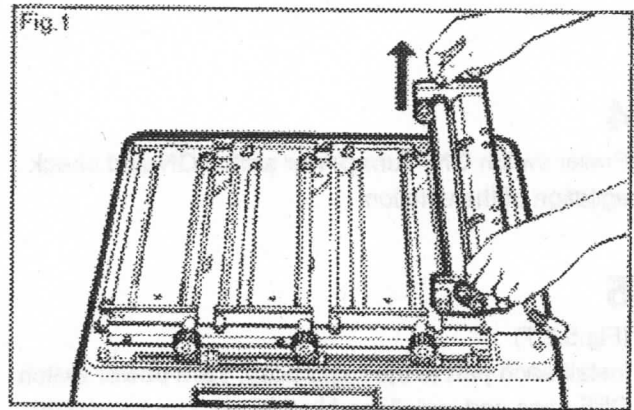
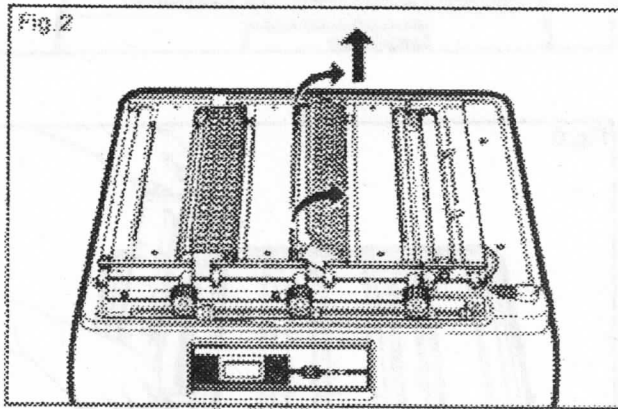

2

Mix processing solution. Mix 2 liters (1/2 gallon) of processing solution with the temperature of the solution 1~2 C deg. higher than the set temperature.

3

(Fig.4) Pour solution into each bath. Insert the tip of the funnel provided into the inlet port on the bottom of the bath and pour solution up to the level line of the No.3 bath, No.2 bath and then the No.1 bath. Keep any processing solution left over for replenishment. "Caution!" Care should be taken against "splashing" of the No.2 and No.3 chemicals with the No.1 chemical which will cause contamination and adverse results. If any solution is splashed into the No.1 bath, it should be wiped o" clean. To prevent contamination, use the separate funnel for each bath and thoroughly wash the funnel after each use.

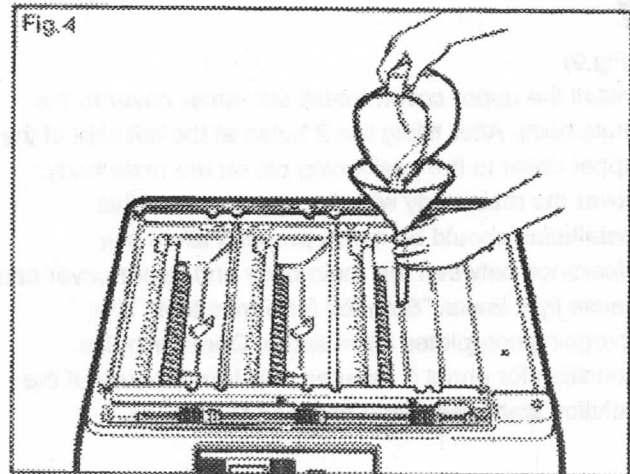

4

Power switch ON. Turn power switch ON and check agitation of the solution.

5

(Fig.5,6,7)

Install each part to the main body. Turn power switch OFF once and install the No.1 to No.3 racks and the inlet rack to the main body. Then insert the inlet rack cord to the connector of the main body. "Caution!" Make sure there is no water on the roller of the inlet rack. Water clinging to the roller can be the cause of developing stains. Wipe the roller with a dry, soft cloth if any water is found on it. Wipe clean any water on the cross-over guides 1,2 and set in rack. Any water on the cross-over guides can be the cause of developing stains.

6

Check the functioning of the drive gear. (Fig.8) Turn power switch ON and make sure the drive gears of each rack are functioning properly. Be sure the slit of the rack drive gear shaft is mated to the positioning plate of the main body.

7

(Fig.9)

Install the upper cover. Install the upper cover to the main body. After fitting the 2 holes at the left side of the upper cover to the positioning pin on the main body, cover the main body with the upper cover. This installation should be made properly since any clearance between the main body and upper cover can cause light leaks. "Standby for 5 minutes!" The foregoing completes initial setup. Operate in this condition for about 5 minutes until temperature of the solution stabilizes. Then proceed to develop.

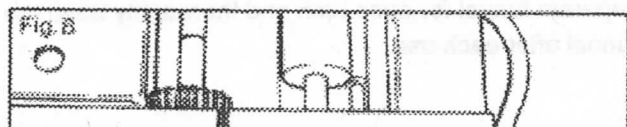
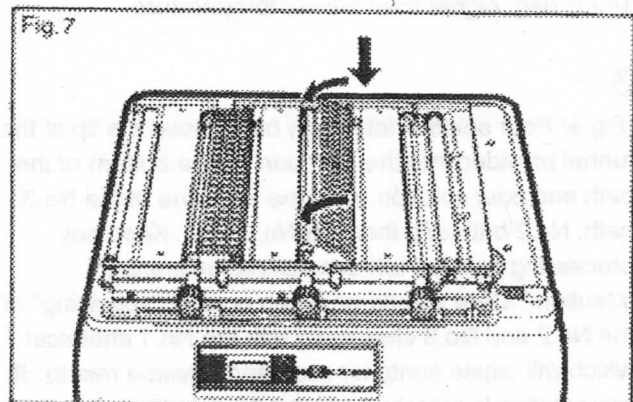
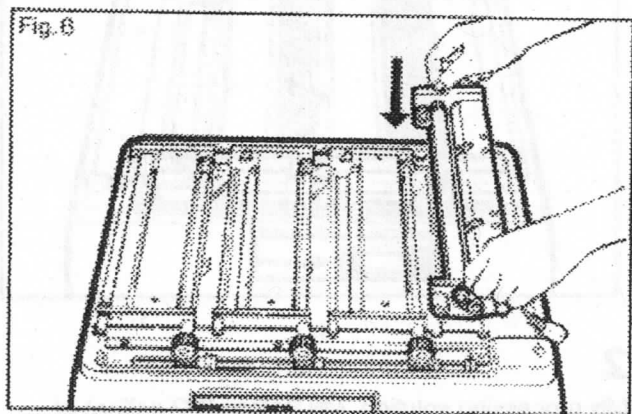
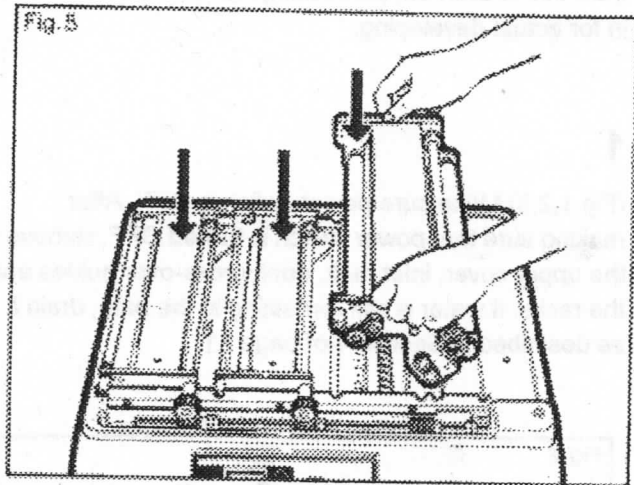

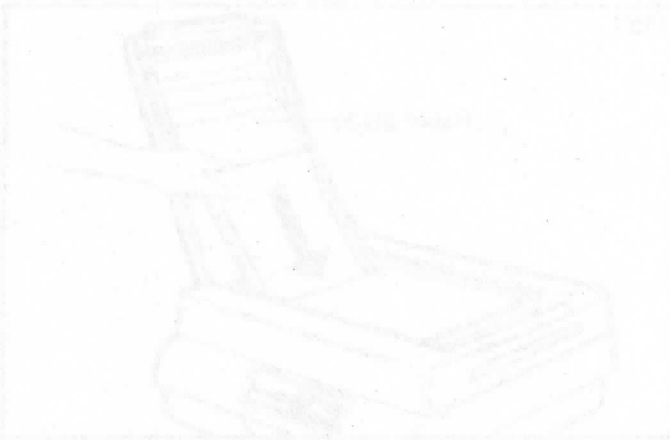
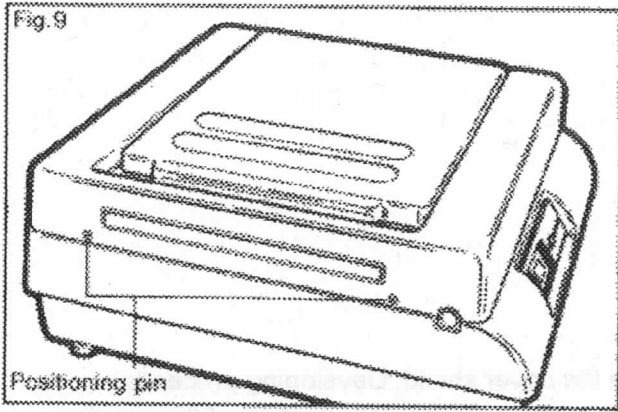

The top cover is a flat panel
Open the cover slowly in a slight arc
and slide it away along the hinge
pins with outward pressure.
CP-31 is capable of processing
film 35mm x 45mm (1.38in x
1.77in) up to 18 (180mm x
135mm) frames. The CP-31 will
not accept film without perforations
on either edge of the film. The
width of the film should be
checked to make sure it will
fit into the machine.
If you are using a paper
negative, the paper is
about 1mm thick. The
paper will not be
drawn into the machine
if it is too thick.

DEVELOPING

Insert paper into the CP-31 in a dark room. Close the cover shield. Developing proceeds automatically. Turn power switch ON and develop. Make sure that temperature of the solution has stabilized.

1

(Fig.1) Insert paper in a dark room. Open the cover shield in a dark room and slide it slowly along the paper guide with emulsion side up. The CP-31 is capable of developing sizes from 3 1/2 x 4.5 inches (83mm x 108mm) up to 12" x 16" (305mm x 406mm). "Caution!" The CP-31 will not accept and develop papers with an overall length of less than 108mm and width of less than 40mm. Extra care should be taken with test prints of small sizes. Be careful not to fingerprint the paper's emulsion. Insert small papers straight. The paper will insert properly by inserting it slowly from the end of the paper guide. (Fig.2)

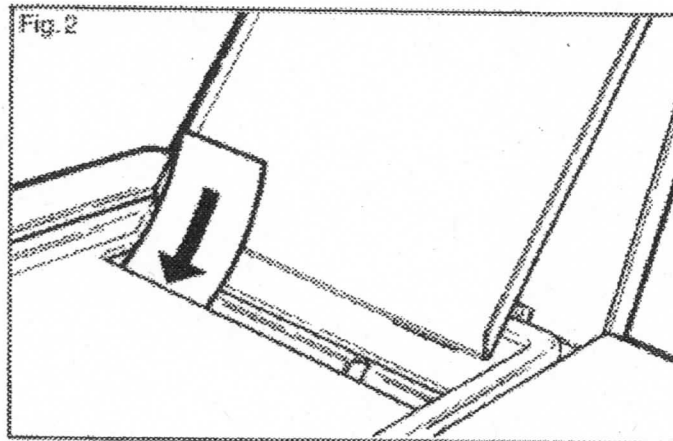
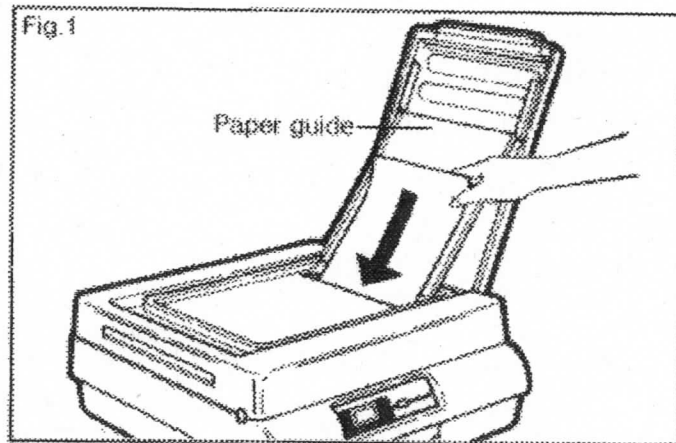

2

(Fig.3)

Check lighting of the paper sensor lamp. When paper enters the inlet rack and the sensor (infrared photo sensor) responds, the sensor lamp will light to indicate that paper is being fed through the inlet rack. "Caution!" (Fig.4) The sensor (infrared photo sensor) will not respond with narrow width papers. Insert the paper so that it will pass through the place marked with the arrow mark. Making sure the sensor lamp lights up. Do not insert narrow papers in the center part of the paper guide. A standby condition may occur during processing if a narrow width paper is developed without passing through the paper sensor. Turn OFF the power switch if this happens. The standby will release by turning switch ON again.

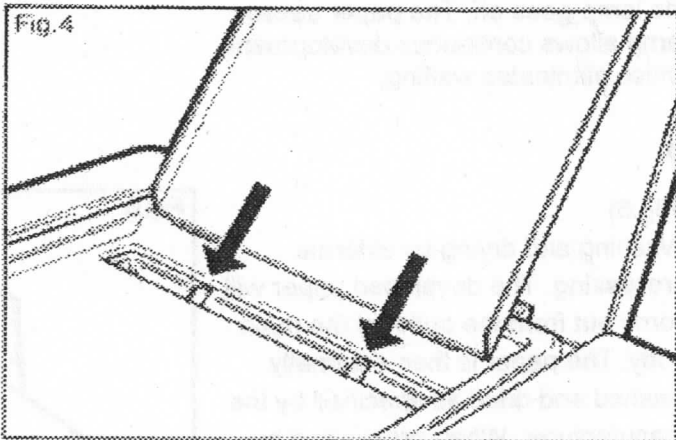
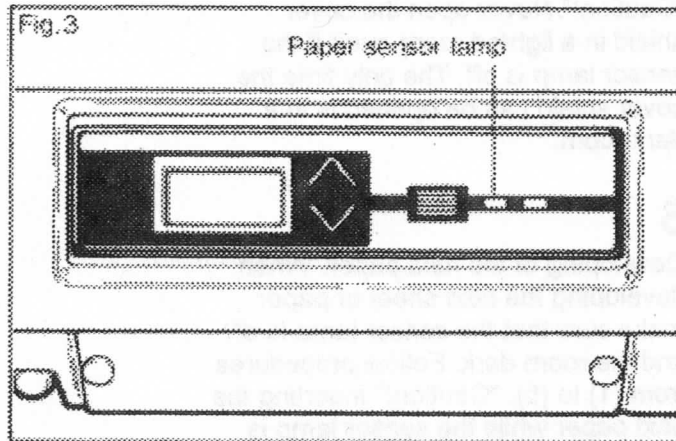
**3**

(Fig.5)

Close cover shield. Close the cover shield after making sure that the paper sensor lamp is ON.

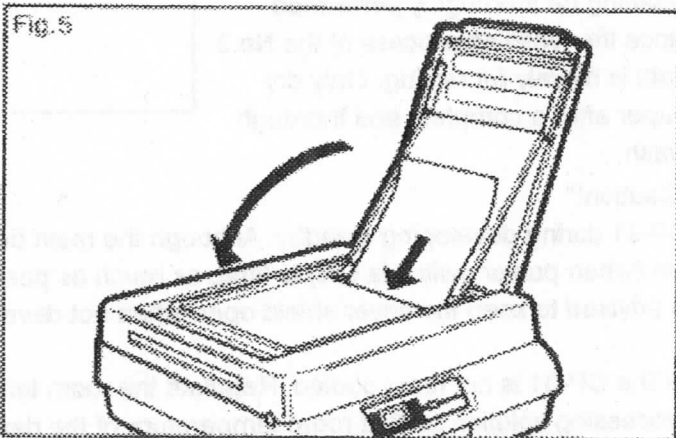
**4**

Processing can now be done in ordinary room light. The machine is light tight once the cover shield is closed. Processing is automatic through each bath.

5

Paper sensor lamp will go off. When the sensor lamp turns off, it shows that the paper has passed through the inlet rack completely and that the next sheet of paper can be inserted.

"Caution!" Never open the cover shield in a lighted room even if the sensor lamp is off. The only time the cover shield can be opened is in a dark room.

6

Developing of the next paper. When developing the next sheet of paper, make sure that the sensor lamp is off and the room dark. Follow procedures from (1) to (5). "Caution!" Inserting the next paper while the sensor lamp is on will cause overlapping of the prints. Always start the next print after the lamp goes off. The paper sensor lamp allows continuous development, which eliminates waiting.

7

(Fig.6)

Washing and drying by external processing. The developed paper will come out from the outlet of the main body. The paper is then externally washed and dried as specified by the manufacturer. When processing by 2-bath chemical, it is necessary that washing be thoroughly performed since the washing process of the No.3 bath is merely for rinsing. Only dry paper after a complete and thorough wash.

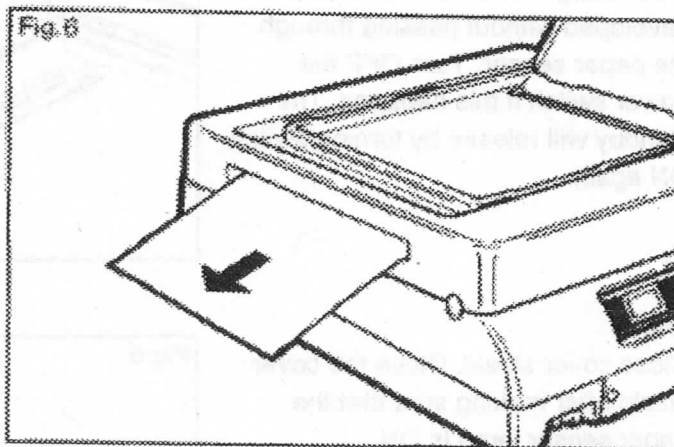

"Caution!"

CP-31 during developing standby. Although the main body is forced ventilated by a ventilation fan (when power switch is ON) to limit, as much as possible, the affects caused by humidity, it is advised to keep the cover shield open when not developing (during standby).

● The CP-31 is not force cooled. Regulate the room temperature or the set temperature of the processing solution so that room temperature of the dark room is 5 C deg. lower than the set temperature of the processing solution.

● Standby Mechanism When not developing for 45 minutes with the power switch ON, the CP-31 goes into standby mode and the roller drive motor and the agitation pump will intermittently operate for 3 seconds at an interval of every 15 seconds. When paper is inserted into the inlet rack and the paper sensor lamp lights, the intermittent operation will release and continuous operation will resume. In case of small size paper, be sure it passes above the

paper sensor as described in 2 of this page.



DRAWING

1

2

3

4

5

6

7

8

9

10

11

12

13

14

15

16

17

18

19

20

21

22

23

24

25

26

27

28

29

30

31

32

33

34

35

36

37

38

39

40

41

42

43

44

45

46

47

48

49

50

51

52

53

54

55

56

57

58

59

60

61

62

63

64

65

66

67

68

69

70

71

72

73

74

75

76

77

78

79

80

81

82

83

84

85

86

87

88

89

90

91

92

93

94

95

96

97

98

99

100

DRAINING

Drain the entire amount of solution from each bath immediately after use. Solution remaining in the bath can crystallize and cause failure of machine parts.

1

Power switch OFF.

Be sure to turn the power switch OFF. Solutions will not drain if the power switch is On.

2

(Fig. 1)

Drain solution.

Pull out the three drain hoses located at the bottom of the main body.

Remove the drain cap and place the hose in a container of more than 2 liters (1/2gallon). Drain solutions from each bath. "Caution!" Solutions will rush out from the hose when removing the drain cap. Be careful not to spill it.

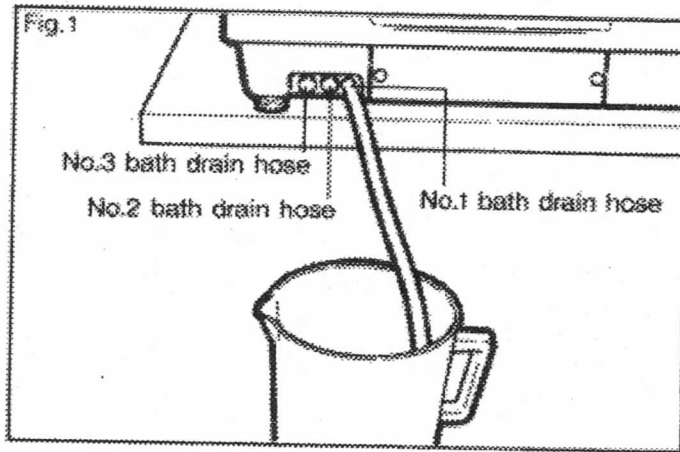

3

Install cap.

Install the drain cap. Be sure to clean the inside of each bath, each rack and cross-over guides according to procedure of CLEANING

CLEANING

Clean each bath and the racks immediately after use. Without washing, failure of the equipment from crystallization may occur. "Caution!" Failure caused by poor cleaning is not covered by the warranty. Please clean completely to keep your equipment in top condition for years of long term service.

1

Turn power switch OFF and drain the entire amount of solution according to procedure of page 16.

2

Remove each part. Remove the upper cover, cross-over guide 1 and 2, inlet rack and the No.14No.3 racks from the main body.

3

Washing of the inlet rack is strictly prohibited. (Fig.1).

Wipe the soiled parts such as the roller, guide plate of the inlet rack lightly with a wet and soft cloth. "Caution!" Never wash the inlet rack with water as electrical parts are attached to it. washing the inlet rack with water can cause trouble. Be sure to fully dry the electrical parts before use if water is found on them.

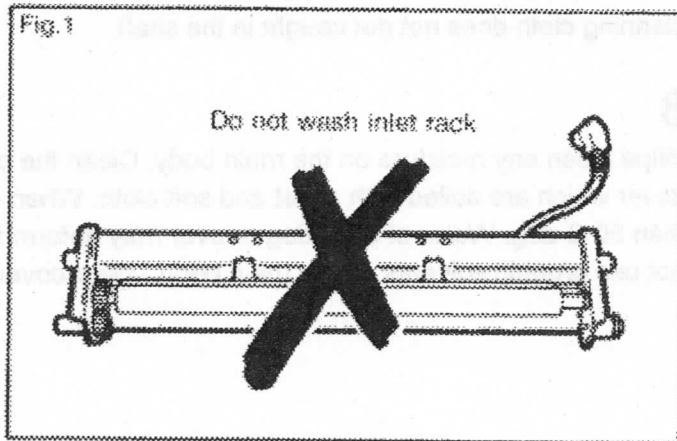

4

(Fig.2)

Washing of rack. Wash the removed racks and cross-over guides with running water or with a shower to thoroughly wash off solution from the racks. Thoroughly wash the roller, gear and bearings in particular, while turning the roller with your hand. "Caution!" Wash the racks and cross-over guides separately so that solution will not adhere to other parts.

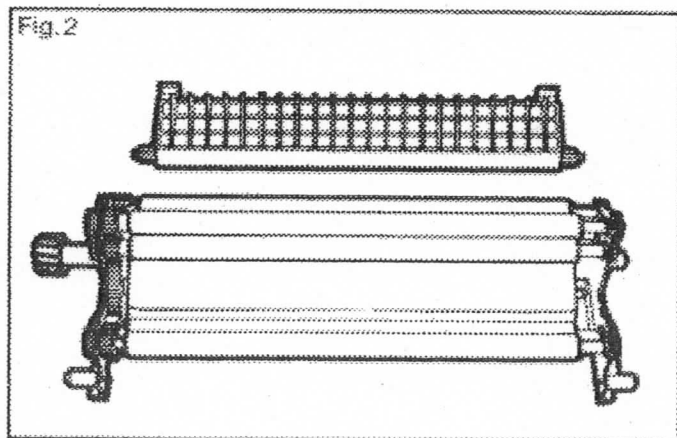

5

Dry each rack. Dry the racks which have been cleaned thoroughly by natural drying. Avoid drying with the racks or cross-over guides installed since moisture will be retained.

6

Next, wash each bath. Place the drain cap on the hose and pour hot water (about 30 C deg.) into each bath.

7

Washing of bath. Turn power switch ON, agitate the hot water and wash the pump, hose and the inside of the nozzle by agitation. After running for about 243 minutes, turn power switch OFF to stop running and drain water with the drain hose. Repeat this at least more than 3 times. After washing is finished, wipe clean of any moisture that remains.

"Caution!"

Be careful so that water does not enter into the gearbox. The drive shaft will turn when the power switch is turned ON and since the rack is removed, care should be taken so that the cleaning cloth does not get caught in the shaft.

8

Wipe clean any moisture on the main body. Clean the outside of the main body and upper cover which are soiled with a wet and soft cloth. When cleaning, do not use hot water of more than 50 C deg. Water of 50 C deg or over may deform the plastic parts used in the CP-31. Do not use organic solvents on the main body, upper cover and on various other plastic parts.

